

889 Advance Post

With Standard Width Webbing

Stylish and sleek design. Features the universal base, with the lowest leading edge on the market - enabling accessibility for all. Ideal for a variety of applications.

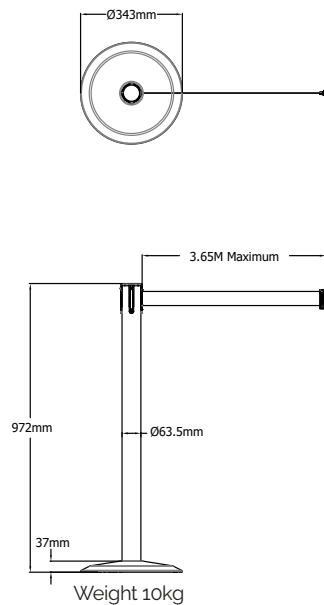
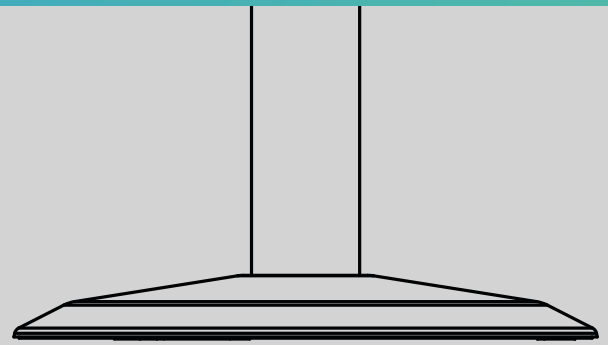

Features & Benefits

- The advance post features a high quality steel post with a hard wearing cast iron base which has been designed with accessibility in mind.
- The edges of the base taper towards the floor to ensure wheelchairs, pushchairs and suitcases can roll over the base with ease - creating a less obstructive queue environment.
- Optimum post height, ensuring difficulty for customers to go underneath or over the webbing barrier.
- The safest barrier on the market - our cassettes have a unique braking system for slower webbing retraction.
- 36° displacement angle, preventing the post from easily toppling over.

Product Specification

- Metal post available in a range of powder coated colours or metal finishes.
- Available with any Tensator® standard (50mm) webbing options.
- Modular webbing cassette - all cassettes come as standard with our four-point anti-tamper connectivity. This allows you to connect other Tensabarrier® products to the receiver splines on the cassette head.
- Comes as standard with an anti-tamper tape end.
- Compatible with all Tensabarrier® accessories including our range of post top signage and wall clips.

Applications

- Enhance and manage queuing spaces.
- Cordon off out of service areas.
- Ideal for a variety of applications including: airports, retail outlets, hotels, casinos, movie theatres.

Order Code

- 88gU-STD - Advance Post with Universal Base 2.3m
- 88gU-MAX - Advance Post with Universal Base 3.65m

Product Configuration

Base Options



Seven base options available

Post Finishes



Full range of metal and powder coated colours available

Webbing Options

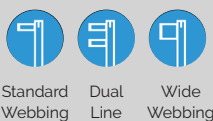

Standard Webbing 50mm width
Dual Line 50mm width (each line)
Wide Webbing 150mm width

Webbing Lengths

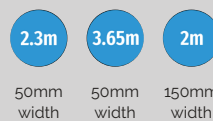

2.3m 50mm width
3.65m 50mm width
2m 150mm width

Webbing Designs



Range of colours, designs and custom options

Tape End Options

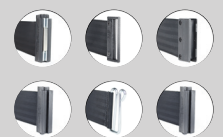

Six tape end options available

MILTON KEYNES
+44 1908 684 600

NEW YORK
+1-800-441-0019

DUBAI
+971 4 2997 228

PARIS
+33 1 43 09 85 00

FRANKFURT
+49 69 3003 89 010

WROCLAW
+48 71 359 3800